

BLUETOOTH WIRELESS STEREO SPEAKER



USER MANUAL

SMPS-625

**PLEASE READ THIS USER MANUAL COMPLETELY BEFORE OPERATING THIS
SPEAKER AND RETAIN THIS BOOKLET FOR FUTURE REFERENCE.**

DEAR JENSEN® CUSTOMER

Selecting fine audio equipment such as the unit you've just purchased is only the start of your musical enjoyment. Now it's time to consider how you can maximize the fun and excitement your equipment offers. This manufacturer and the Electronic Industries Association's Consumer Electronics Group want you to get the most out of your equipment by playing it at a safe level. One that lets the sound come through loud and clear without annoying blaring or distortion and, most importantly, without affecting your sensitive hearing. Sound can be deceiving. Over time your hearing "comfort level" adapts to higher volumes of sound. So what sounds "normal" can actually be loud and harmful to your hearing. Guard against this by setting your equipment at a safe level BEFORE your hearing adapts.

To establish a safe level:

- Start your volume control at a low setting.
- Slowly increase the sound until you can hear it comfortably and clearly, and without distortion.

Once you have established a comfortable sound level:

- Set the dial and leave it there.

Taking a minute to do this now will help to prevent hearing damage or loss in the future. After all, we want you listening for a lifetime.

We Want You Listening For a Lifetime

Used wisely, your new sound equipment will provide a lifetime of fun and enjoyment. Since hearing damage from loud noise is often undetectable until it is too late, this manufacturer and the Electronic Industries Association's Consumer Electronics Group recommend you avoid prolonged exposure to excessive noise.



Customer's Record:

The serial number of this product is found on its back cover. You should note the serial number of this unit in the space provided as a permanent record of your purchase to aid in identification in the event of theft or loss.

Model Number: SMPS-625

Serial Number: _____

COMPLIANCE WITH FCC REGULATIONS

This device complies with Part 15 of the FCC Rules. Operation is subject to the following two conditions:

- (1) this device may not cause harmful interference, and
- (2) this device must accept any interference received, including interference that may cause undesired operation.

NOTE : This equipment has been tested and found to comply with the limits for a Class B digital device, pursuant to Part 15 of the FCC Rules. These limits are designed to provide reasonable protection against harmful interference in a residential installation. This equipment generates, uses and can radiate radio frequency energy and, if not installed and used in accordance with the instructions, may cause harmful interference to radio communications. However, there is no guarantee that interference will not occur in a particular installation. If this equipment does cause harmful interference to radio or television reception, which can be determined by turning the equipment off and on, the user is encouraged to try to correct the interference by one or more of the following measures:

- Reorient or relocate the receiving antenna.
- Increase the separation between the equipment and receiver.
- Connect the equipment into an outlet on a circuit different from that to which the receiver is connected.

- Consult the dealer or an experienced radio/TV technician for help.

CAUTION: Changes or modifications not expressly approved by the party responsible for compliance could void the user's authority to operate the equipment.

PROTECT YOUR FURNITURE

This model is equipped with non-skid rubber 'feet' to prevent the product from moving when you operate the controls. These 'feet' are made from non-migrating rubber material specially formulated to avoid leaving any marks or stains on your furniture. However certain types of oil based furniture polishes, wood preservatives, or cleaning sprays may cause the rubber 'feet' to soften, and leave marks or a rubber residue on the furniture. To prevent any damage to your furniture we strongly recommend that you purchase small self-adhesive felt pads, available at hardware stores and home improvement centers everywhere, and apply these pads to the bottom of the rubber 'feet' before you place the product on fine wooden furniture.

PRODUCT FEATURES

The SMPS-625 is a Bluetooth portable stereo speaker with the following features:

- Wireless playback of music from your Bluetooth enabled device via the Bluetooth connection.
- Hands-free Bluetooth Speakerphone
- Up to 33 feet (10 meters) operating range.
- Auxiliary input jack to play music from your iPod or digital audio player.
- Digital volume control.

GETTING STARTED

ACCESSORIES INCLUDED

Carefully remove the unit and all the accessories from the gift box. Please verify that you have all the following accessories before recycling the gift box.

- User manual
- USB cable
- 3.7V 800mAh rechargeable Li-ion battery

LOCATION OF CONTROLS

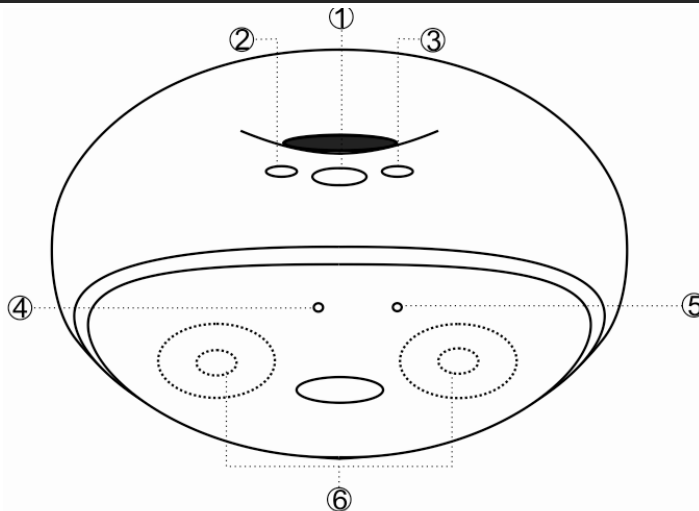

1. PLAY/PAUSE ►|| BUTTON
2. VOLUME UP (-) BUTTON
3. VOLUME DOWN (+) BUTTON
4. BUILT IN MICROPHONE
5. BLUETOOTH STATUS INDICATOR

6. SPEAKERS

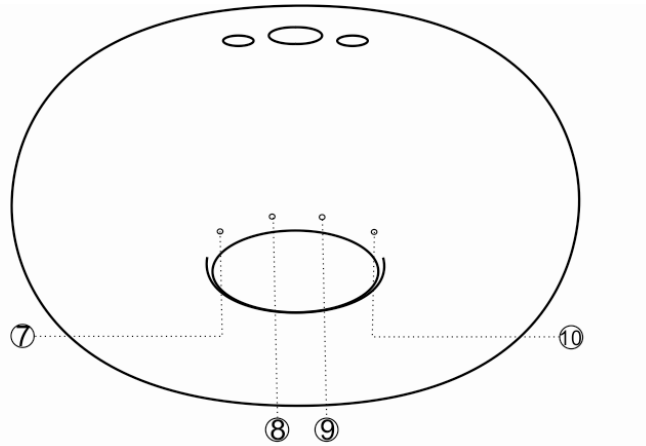

- 7. POWER OFF/BLUETOOTH AND AUX SWITCH
- 8. CHARGING JACK (mini USB jack)
- 9. POWER/CHARGING INDICATOR
- 10. AUX-IN JACK

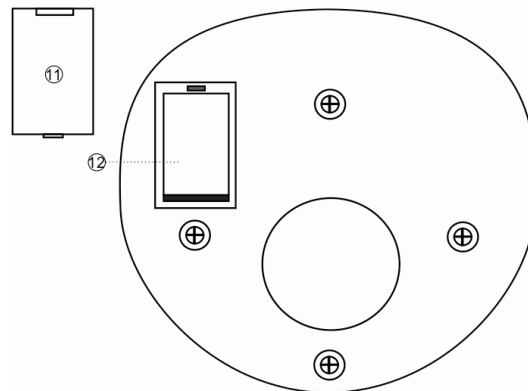

- 11. BATTERY COMPARTMENT DOOR
- 12. BATTERY COMPARTMENT

CHARGING INSTRUCTIONS

This unit operates on a rechargeable Li-ion battery (included). Open the Battery Compartment Door. Follow the engraved diagram inside the Battery Compartment to properly install the battery. After installing the battery correctly, close the Battery Compartment Door. The unit can now be recharged either using the USB port on your computer or from a USB power adaptor (not included) with a rated output of DC 5V, 500mA and up.

CAUTION:

1. Make sure the battery is installed correctly.
2. Replace only with the same or equivalent type of battery.

Note: The CHARGING JACK located on this unit is only designed for charging the Li-ion battery.

CHARGING THE BATTERY FOR FIRST TIME

- 1.) Charge the Li-ion battery a minimum of 3 hours prior to first use.
Plug the unit into a USB port on your computer or into a USB power adaptor (not included) using the included USB cable.
- 2.) The **POWER/CHARGING** indicator will be red while charging. When the light

turns green, the unit is fully charged. Unplug the USB cable from the power source once the battery is fully charged.

RECHARGING THE BATTERY

After prolonged use, the battery will be weak and operation may become intermittent. When this occurs you need to recharge the battery as soon as possible. Plug the unit into a USB port on your computer or into a DC 5V, 500mA and up, USB power adaptor (not included) using the included USB cable. Disconnect the USB cable from the speaker as soon as it is fully charged.

Charging in Power ON mode

- The Indicator LED is RED while charging.
- The Indicator LED will change from RED to GREEN when the battery is fully charged.

Note:

1. Charging time will vary if you are listening to music while charging the speaker battery. We recommend you turn off the speaker power during the charging process.
2. To prolong the life of a rechargeable battery, it is recommended to completely discharge it before fully charging it again.
3. Rechargeable battery need to be cycled for maximum performance and longer battery life. If you don't use the player that often, be sure to recharge the battery at least once a month in order to keep the internal battery working properly.
4. If the speaker is not used for an extended period of time, remove the battery. An old or leaking battery can cause damage to the speaker and may void the warranty.

Charging in Unit Power OFF mode

- The Indicator LED is RED while charging.
- The Indicator LED will change from RED to GREEN when the battery is fully charged.



Battery Note and Care

- Do not burn or bury batteries.
- Do not puncture or crush.
- Do not disassemble.
- Recycle Li-ion batteries. Do not dispose of in the trash.
- If the electrolyte in the cells should get on your skin, thoroughly wash with soap and water. If in the eyes, rinse thoroughly with cool water. Immediately seek medical attention.
- Use only chargers rated for Li-ion cells. Be sure the charger's voltage and current settings are correct for the battery pack being charged.
- Charge batteries on the fireproof surface away from flammable items or liquids.
- Batteries should NEVER be left unattended while charging. Only adults should charge the batteries.
- Follow the manufacturer's instructions for charging the product and do not charge longer than recommended. Unplug the charger when the battery is charged or not in use.



Recycle Rechargeable Batteries

Recycle your old rechargeable batteries at one of the many collection sites in the U.S. and Canada. To find the site nearest you, visit www.call2recycle.org or call toll-free 1-877-2-RECYCLE

NOTE: The speaker is not magnetically shielded and may cause color distortion on the screen of some TVs or video monitors. To avoid this, you may need to move the unit further away from the TV or monitor if an unnatural color shifts or image distortion occurs.

TURNING THE SMPS-625 POWER ON/OFF

1. In power off mode, slide the **POWER OFF/BLUETOOTH AND AUX SWITCH** to Bluetooth and AUX position to turn the unit ON. After about 3 seconds a beep is heard and **BLUETOOTH STATUS INDICATOR** will flash in blue.
2. To turn the unit OFF, slide the **POWER OFF/BLUETOOTH AND AUX SWITCH** to Power OFF position.

CAUTION: Please turn the power off the when not in use. The battery could completed drained and you will need to recharge the unit before using it again.

OPERATING THE UNIT

Pairing (linking) a Bluetooth enabled call phone or other Bluetooth enabled device to the speaker

1. If the SMPS-625 has never been paired with a Bluetooth device before. You need to follow the pairing instructions below to link the SMPS-625 with your Bluetooth device.
2. In power off mode, slide the **POWER OFF/BLUETOOTH AND AUX SWITCH** to Bluetooth and AUX position. After about 3 seconds a beep is heard and **BLUETOOTH STATUS INDICATOR** will flash in blue. The speaker is now ready to pair (link) with your Bluetooth device.
 - Turn on the Bluetooth function of your Bluetooth device and enable the search or scan function to find the SMPS-625.
 - Select "SMPS-625" from the device list when it appears on your device screen. If required, enter the pass code "0000" to pair (link) the SMPS-625 with your device.
3. After turning on the SMPS-625, a beep is heard and the unit will search for the last paired device. The **BLUETOOTH STATUS INDICATOR** will flash blue. If the speaker finds the paired Bluetooth device, a beep is heard and the **BLUETOOTH STATUS INDICATOR** will stop flashing and remain lit (blue).
4. After successfully pairing (linking), you can begin playing music from your Bluetooth device wirelessly to the speaker.
5. Press the Volume Up(+) / Down(-) button on the speaker to adjust to the desired volume level.

Notes:

1. Refer to manual of your cell phones, tablet PC, computer or other Bluetooth enabled device for Bluetooth operation since it may vary from model to model.
2. Your Bluetooth enabled device will not play the music through the speaker, even if connected (linked), if the device does not support A2DP profile.
3. If you are pairing (linking) your computer to the SMPS-625 using Bluetooth, you may need to set the speaker as your computer's default sound device.
4. If the SMPS-625 is left idle for about 3 minutes without linking to any Bluetooth enabled device, it will automatically turn off to save battery power.

Using the SMPS-625 as a Hands-free Bluetooth Speakerphone

1. Link your cell phone to the SMPS-625 via Bluetooth as described above.
2. When receiving an incoming call on your cell phone, tap the **PLAY/PAUSE ►||** **BUTTON** on the speaker to switch the incoming call from cell phone to the SMPS-625. A short beep sound will be heard confirming the call is being answered. Complete your call using the built-in microphone and speaker on the

SMPS-625.

3. Adjust the volume control on the speaker obtain the desired sound level.
4. To end the call, just tap the **PLAY/PAUSE ►|| BUTTON** again on the SMPS-625. A short beep sound will be heard and the call will end. If you were playing music from your cell phone to the SMPS-625 before answering the call, the music will automatically resume playing when you hang up.
5. To ignore an incoming call, simply press and hold the **PLAY/PAUSE ►|| BUTTON** on the speaker for about 2 seconds, a beep sound will be heard and the call will be ignored.

Note: The sound level in hands-free mode is lower than music playing mode, so in hands-free mode you may need to increase the volume level.

Hang up with the SMPS-625

A quick press on the **PLAY/PAUSE ►|| BUTTON** will end the call in progress. A short beep tone will be heard from the speaker confirming the call has ended.

Redialing the last number with the speaker

The speaker will automatically redial the last number you dialed by tapping the speaker **PLAY/PAUSE ►|| BUTTON** twice and long beep will heard.

Note: This feature is phone dependent.

Re-linking to the cell phone

If your cell phone is already paired (linked) with the SMPS-625, but became unlinked even with both Bluetooth devices turned on. You can re-link them by:

1. Turning off the SMPS-625 and then turning it on again to re-link your cell phone. After 3 seconds a beep will be heard and the **BLUETOOTH STATUS INDICATOR** will flash blue. After 2 more seconds, short beeps will be heard and the **BLUETOOTH STATUS INDICATOR** will stop flashing and remain lit (blue) and a short beep will be heard if the SMPS-625 and your cell phone were successfully re-linked.
2. You can also re-link the speaker by using Bluetooth operation of your cell phone. Please refer to operation manual of your cell phone for more information.

PLAYING MUSIC USING THE AUXILIARY INPUT

The speaker features an auxiliary audio signal input jack for connecting external audio devices like MP3 players, CD players, iPhones or iPods (except iPod shuffle 3rd gen) and listen to them your through the speakers.

1. Use the audio cable (included) with one 3.5 mm stereo plug on each end of the cable.
2. Plug one end into the AUX-IN jack on the SMPS-625 and the other end of the cable into the Line-out Jack or Headphone Jack of your external audio device.
3. Slide the **POWER OFF/BLUETOOTH AND AUX SWITCH** to Bluetooth and AUX position.
4. Turn on your external audio device.
5. Press the VOLUME UP (+) / DOWN (-) button on the SMPS-625 to obtain the desired volume level. Operate all other functions on the external device as usual.

NOTE:

1. If you are connected to the Line Out Jack of your external device then you only need to adjust the volume control on the SMPS-625. If you're connected to the Headphone Jack of your external device, then you may need to adjust both the volume control of your external device and the SMPS-625 to obtain the most desirable volume setting.
2. If you use **AUX IN** function when playing Bluetooth audio, Bluetooth audio will be temporarily disconnected when the audio cable is plugged in. Unplugging the audio cable will resume Bluetooth audio. We suggest you turn off the Bluetooth function to save battery power when playing music via AUX IN

- mode.
- Slide the **POWER OFF/BLUETOOTH AND AUX SWITCH** to Power off position when you finish listening. Don't forget to switch off the power of your external device as well.

CARE AND MAINTENANCE

- Avoid operating your unit under direct sunlight or in hot, humid or dusty places.
- Keep your unit away from heating appliances and sources of electrical noise such as fluorescent lamps or motors.

CLEANING THE UNIT

- To prevent fire or shock hazard, disconnect your unit from the USB port of power source when cleaning.
- The finish on the unit may be cleaned with a dust cloth and cared for as other furniture. Use caution when cleaning and wiping the plastic parts.
- If the cabinet becomes dusty wipe it with a soft dry dust cloth. Do not use any wax or polish sprays on the cabinet.
- If the cabinet becomes dirty or smudged with fingerprints it may be cleaned with a soft cloth slightly dampened with a mild soap and water solution. Never use abrasive cloths or polishes as these will damage the finish of your unit.

CAUTION: Never allow any water or other liquids to get inside the unit while cleaning.

TROUBLESHOOTING GUIDE

Symptom	Possible Problem	Solution
No Charging	The USB power adaptor (not included) is not plugged into a wall outlet or the USB cable (included) is not plugged into the mini USB jack on the SMPS-625.	Plug the USB power adaptor (not included) into a wall outlet and plug the USB cable (included) into the mini USB jack on the SMPS-625.
	Wall outlet is not functioning.	Plug another device into the same outlet to confirm the outlet is working.
	Computer USB port is not functioning.	Make sure your computer power is turned on and try another USB port.
No Sound	The SMPS-625 battery is dead.	Recharge the SMPS-625 battery.
	The SMPS-625 is not linked with the Bluetooth enabled device.	Go through "Operating the Unit" process to link the speaker.
	The SMPS-625 placement out of range.	Relocate the SMPS-625 within Bluetooth operating range (30 feet).
	Volume set too low.	Press the Volume + button to turn the sound level up.
Sound is distorted.	Volume level is set too high.	Decrease the volume of the speaker.
	Sound source is distorted.	If the source sound file is of poor quality, distortion and noise are easily noticed with high-power speakers. Try a different audio source such as a music CD. If you are using an external sound source like older generation of iPod, try reducing the output volume on the device itself. Also try turning bass boost OFF or change the EQ

		setting.
Unit gets warm after extended play at high volume.	This is normal.	Turn the speaker off for a period of time or lower the volume.

SPECIFICATIONS

Power Requirement

Main unit

DC 3.7V 800mAh rechargeable Li-ion Battery



At Spectra, environmental and social responsibility is a core value of our business. We are dedicated to continuous implementation of responsible initiatives with an aim to conserve and maintain the environment through responsible recycling.

Please visit us at <http://www.spectraintl.com/green.htm> for more information on Spectra's green initiatives or to find a recycler in your area.

Bluetooth® is a registered trademark of Bluetooth SIG, Inc.

90 DAY LIMITED WARRANTY AND SERVICE

VALID IN THE U.S.A. ONLY

SPECTRA MERCHANDISING INTERNATIONAL, INC. warrants this unit to be free from defective materials or factory workmanship for a period of 90 days from the date of original customer purchase and provided the product is utilized within the U.S.A. This warranty is not assignable or transferable. Our obligation under this warranty is the repair or replacement of the defective unit or any part thereof, except batteries, when it is returned to the SPECTRA Service Department, accompanied by proof of the date of original consumer purchase, such as a duplicate copy of a sales receipt.

You must pay all shipping charges required to ship the product to SPECTRA for warranty service. If the product is repaired or replaced under warranty, the return charges will be at SPECTRA's expense. There are no other express warranties other than those stated herein.

This warranty is valid only in accordance with the conditions set forth below:

1. The warranty applies to the SPECTRA product only while:
 - a. It remains in the possession of the original purchaser and proof of purchase is demonstrated.
 - b. It has not been subjected to accident, misuse, abuse, improper service, usage outside the descriptions and warnings covered within the user manual or non-SPECTRA approved modifications.
 - c. Claims are made within the warranty period.
2. This warranty does not cover damage or equipment failure caused by electrical wiring not in compliance with electrical codes or SPECTRA user manual specifications, or failure to provide reasonable care and necessary maintenance as outlined in the user manual.
3. Warranty of all SPECTRA products applies to residential use only and is void when products are used in a nonresidential environment or installed outside the United States.

This warranty gives you specific legal rights, and you may also have other rights which vary from state to state. TO OBTAIN SERVICE please remove all batteries (if any) and pack the unit carefully and send it freight prepaid to SPECTRA at the address shown below. IF THE UNIT IS RETURNED WITHIN THE WARRANTY PERIOD shown above, please include a proof of purchase (dated cash register receipt) so that we may establish your eligibility for warranty service and repair of the unit without cost. Also include a note with a description explaining how the unit is defective. A customer service representative may need to contact you regarding the status of your repair, so please include your name, address, phone number and email address to expedite the process.

IF THE UNIT IS OUTSIDE THE WARRANTY PERIOD, please include a check for \$25.00 to cover the cost of repair, handling and return postage. All out of warranty returns must be sent prepaid.

It is recommended that you contact SPECTRA first at 1-800-777-5331 or by email at custserv@spectraintl.com for updated information on the unit requiring service. In some cases the model you have may be discontinued, and SPECTRA reserves the right to offer alternative options for repair or replacement.

SPECTRA MERCHANDISING INTERNATIONAL, INC.
4230 North Normandy Avenue,
Chicago, IL60634, USA.
1-800-777-5331

To register your product, visit the link on the website below to enter your information.

<http://www.spectraintl.com/wform.htm>

0812

Printed in China